

Using a Substitution Measurement Topology to Eliminate the Effect of Common Mode Errors in Resistance Measurements used in Temperature Metrology

Speaker: Paul Bramley, Metrosol Limited, 41 Hazel Crescent, Towcester, NN12 6UQ, UK.
Tel: +44 (0)1327 351444 Fax: +44 (0)1327 351444 Email: paul.bramley@metrosol-ltd.co.uk

Authors: Paul Bramley, Metrosol Limited. John Tavener, Isothermal Technology. John Pickering, Metron Designs Limited.

Abstract

This article discusses the advantages of using a substitution measurement topology in place of the conventional common-current series connection arrangement employed in bridges or potentiometric resistance instruments working at the highest (sub ppm) accuracies. Most high accuracy resistance instruments pass a common AC or DC current through the device-under-test (DUT) and a reference standard (REF). The ratio of the resistance of the DUT to that of the REF is determined by balancing a bridge circuit or by taking successive measurements of the voltage across the DUT and REF with a highly linear voltmeter. However, both these techniques are prone to the effect of common-mode signals in the bridge circuit or the differential amplifier used with the voltmeter. An alternative measurement topology is discussed in which the DUT and REF are alternately switched into the same measurement point in the instrument in order to avoid common mode changes between measurements on the REF and DUT. Unfortunately, this approach significantly increases the performance demands on the current source used to generate the sense current and this would normally result in comparable errors to those from the common-mode problems we are trying to overcome. However, by using a cascode amplifier between the current source and the measurement point and by employing active guarding this pitfall is avoided. This technique is employed in the new microK range of resistance bridges developed for temperature metrology applications. This paper and the performance results show how this technique allows the instruments to take full advantage of the high linearity and speed of the ADC developed for the products in order to achieve sub milli-Kelvin uncertainties. Although this paper discusses the application of the principle to resistance measurement, it can equally be applied to the measurement of other parameters such as capacitance or inductance.

1 Introduction

Conventional wisdom is that the most accurate resistance measurements (typically below 1ppm) are made using a bridge. The use of bridges pre-dates the electronics era and allowed surprisingly accurate resistance measurements to be made with purely electrical devices. Probably the most well known is the Wheatstone bridge, which was developed by Charles Wheatstone in 1843 (Figure 1).

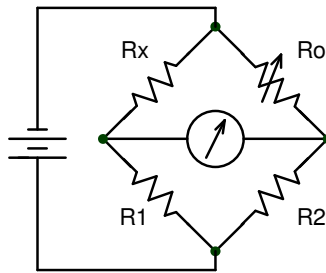

Figure 1: Wheatstone bridge.

The bridge is balanced (R_o adjusted until the galvanometer/detector reads zero). The unknown resistor R_x is then easily determined from the known resistors R_o , R_1 and R_2 . The symmetry of the Wheatstone bridge means that the measurement is not affected by supply noise as this is common to both ‘arms’ of the bridge and at balance is not seen by the detector. Also, the detector performance is not critical to the measurement; it is only required adequately to detect a null balance.

The Kelvin double bridge [1] and Warshawsky bridge [2] are variants of the basic Wheatstone bridge that respectively allow the partial or full use of four wire resistors and provide very useful measurement arrangements.

The most accurate resistance measurements made in thermometry are presently made using transformer based, ratio bridges (Figure 2):

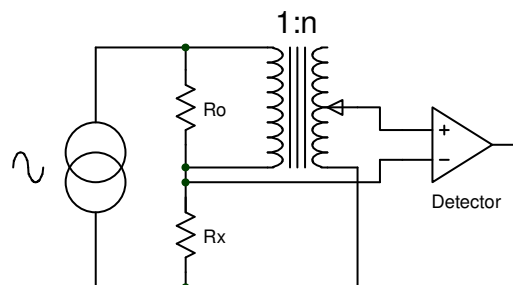

Figure 2: AC ratio transformer bridge.

The ratio transformer (actually a series of cascaded, interconnected transformers to achieve the resolution) has a tapped secondary and the bridge is balanced by adjusting the tapplings selected. At balance, the voltage on the transformer secondary is equal to the voltage across R_x . Since the ratio of the voltage across the primary and secondary of an ideal transformer is equal to the turns ratio, the ratio of the resistances R_x and R_o equals the turns ratio ($R_x = nR_o$) [3].

A simpler topology uses a voltmeter to make a potentiometric measurement (Figure 3):

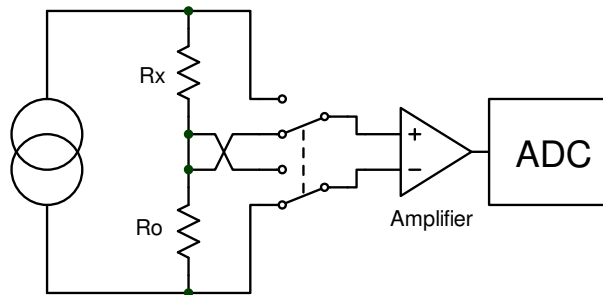

Figure 3: Potentiometric resistance instrument.

The amplifier and Analog-to-Digital Converter (ADC) are alternately connected to measure the voltage across the two resistances, R_x and R_o . The unknown resistance is then the product of the known resistance and the ratio of these two voltage measurements ($R_x = R_o V_x / V_o$).

All three of the above measurement topologies share some key characteristics, the most important being that the DUT and reference resistor are connected (in series) to a common current/voltage source. This means that the current in the DUT and reference resistor is the same (provided that the bridge is balanced, in the case of the Wheatstone bridge). Since all the measurements are essentially voltage measurements or balancing systems, this allows the resistance ratio to be determined accurately. Additionally, all three involve some change in the common mode voltages of key components during the measurement and this can lead to errors.

2 Common Mode Errors

In the Wheatstone bridge, the common mode signal at the detector changes with R_x . In the original implementation, the detector was a galvanometer and this change would not have adversely affected the measurement accuracy. In more modern derivatives of the Wheatstone bridge, the detector is likely to be electronic in order to achieve a higher performance. This change in common mode voltage is likely to lead to non-linearities that are significant when trying to achieve this higher performance. This type of error cannot easily be compensated for during calibration and will ultimately limit the performance of the bridge.

In the case of the AC ratio transformer bridge, the common mode signal on the secondary of the transformer is different to that on the transformer primary. This means that the bridge will not inherently read unity when the DUT and reference are the same. Typically this error is adjusted out during calibration. This common-mode signal error will be very stable with time and temperature (since it depends on the position of the conductors and dielectric materials used in the transformer). However, the adjustment will usually involve using a potentiometer and the stability of the adjustment system represents a potential source of drift with time, albeit small in any well designed instrument.

In the case of the potentiometric measurement technique, the common mode signal at the input to the pre-amplifier changes between the two measurements, leading to scale errors and/or non-linearities. For example, the amplifier in an instrument of this type might achieve a Common-Mode Rejection Ratio (CMRR) of 120dB. Whilst this represents a good CMRR figure, this would lead to scale errors of 1ppm.

3 The Substitution Topology

The new microK precision thermometry instrument employs a new type of metrology grade sigma-delta ADC with a linearity of 0.2ppm, high speed and exceptionally low noise [4]. In order to take advantage of the performance offered by this new ADC, a substitution topology was employed (Figure 4) that eliminates the common-mode errors associated with more conventional arrangements.

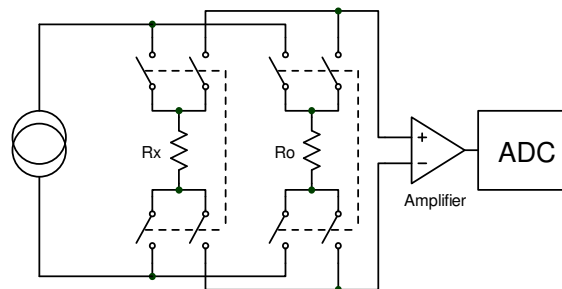

Figure 4: Substitution topology.

The substitution topology has only a single measurement position into which the DUT (R_x) and reference (R_o) are switched alternately. This has the effect of eliminating any change in common mode voltage between measurements on the two devices (contrast this with the conventional potentiometric technique). The effect of this is that the measurements are inherently accurate and stable at both zero and unity ratio.

3.1 Zero Errors

In common with other high accuracy potentiometric or ‘DC’ bridge instruments, the microK eliminates the effect of thermal EMFs (EMFs generated as the result of dissimilar metals and temperature gradients) by taking two measurements (V_1 and V_2) and reversing the current (I) between them. Averaging the magnitude of the readings yields a result that is the voltage developed across the resistance R without any contribution from the thermal EMFs (e):

$$\begin{aligned}V_1 &= IR + e \\V_2 &= -IR + e \\ \frac{V_1 - V_2}{2} &= \frac{(IR + e) - (-IR + e)}{2} = IR\end{aligned}$$

The process of current reversal and averaging, together with true 4-wire resistance measurement has the effect of ensuring an intrinsically stable zero with time and temperature (the voltage at the Amplifier input when measuring a short-circuit will be the same whichever current direction is used). The process of averaging (the magnitude of) the measurements therefore yields an inherent zero, with uncertainty determined by the system noise.

3.2 Unity Ratio Errors

Similarly, the substitution topology also ensures that the measurements are inherently accurate and stable at unity ratio. At unity ratio, the voltages measured for the DUT and reference (of the same value) will be identical. There is, after all, no difference between these two measurements apart from the fact that they are taken at slight different times. The calculated resistance ratio will therefore be (inherently) unity with the system noise again determining the uncertainty of this unity ratio measurement.

3.3 Problems with Implementing a Substitution Topology

As with most things, there is a price to pay for this improved performance. In the case of the substitution topology, there is an increase in the complexity of the measurement arrangement (there are twice the number of single pole switching elements in figure 4 compared with figure 3). There is also a considerable extra demand on the performance of the current source, which needs to maintain a constant current between the two measurements to a level well below the target specification ($<0.4\text{ppm}$ in the case of the microK). Although these factors add complexity and therefore cost to the instrument, the performance benefits are considerable for what is a modest increase in cost.

3.3.1 Errors Caused by the Current Source in Substitution Topology

In the more traditional topologies (for example the potentiometric topology shown in figure 3), the current is common to both the DUT (R_x) and reference resistor (R_o). This means that the current source does not experience any change in load during the measurement and the only requirement is that it should remain constant during the measurement time. By contrast, the load on the current source in the substitution topology changes between the DUT and reference and it must maintain a substantially constant current under such a changing load. This problem may be modeled by considering the current source to be equivalent to an ideal current source shunted by an output impedance (R_i), as shown in figure 5:

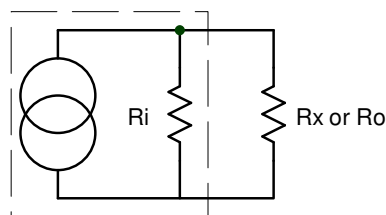

Figure 5: Effect of current source output impedance.

As discussed above, the substitution topology means that there is no error in the measured ratio, at zero or unity ratio, due to the finite output impedance R_i (the 'errors' caused by R_i affect both measurements in the ratio equally when $R_x = R_o$ and have no effect when $R_x = 0$). At ratios other than zero or unity, the output impedance affects the two measurements made (with the current source connected to either R_x or R_o) differently. The resulting error in the measured ratio is given by:

$$Error = \frac{R_x}{R_0} \left[\frac{1 - \frac{R_x}{R_0}}{\frac{R_i}{R_0} - \frac{R_x}{R_0}} \right]$$

However, since $R_i \gg R_x$, this approaches:

$$Error \approx \frac{R_0}{R_i} \left[\frac{R_x}{R_0} \left(1 - \frac{R_x}{R_0} \right) \right]$$

This error function is parabolic (figure 6):

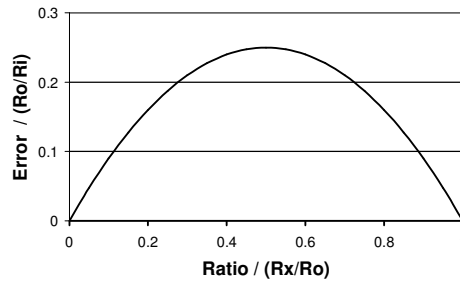

Figure 6: Error from current source impedance.

As R_x varies between 0 and R_0 , the maximum error (when $R_x = R_0/2$) is:

$$Maximum\ Error\ (Ratio\ Range\ 0 - 1) = \frac{R_0}{4R_i}$$

The measurements requiring the greatest accuracy in thermometry are typically made with a 25Ω SPRT and a 100 ohm reference resistor. In this case, the accuracy of the microK ($<0.4\text{ppm}$) requires that the output impedance of the source should be $R_i \gg 62.5\text{M}\Omega$.

3.3.2 The microK Current Source

At first sight, the effect of the output impedance of the current source appears to negate the advantages of the topology since errors from this effect would normally be comparable to those from the common-mode problems we are trying to overcome. However, by using a combination of a cascode stage between the current source and the measurement point and by employing active guarding this pitfall is avoided.

The current source in the microK uses the standard arrangement shown in figure 7.

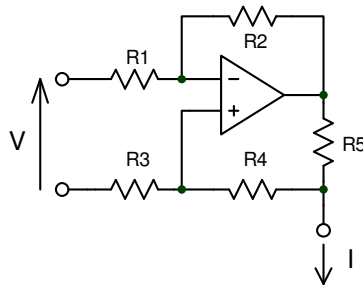

Figure 7: Basic current source.

The circuit produces a ‘constant’ current (I) proportional to the input voltage (V). The output impedance is primarily determined by the gain of the amplifier and the matching of the resistors $R1$ to $R4$. An analysis of this circuit as implemented in the microK shows that taking the most adverse imbalance in the resistors values, the output impedance would be $9\text{M}\Omega$ at 1mA . This would in turn lead to a maximum error of 2.8ppm for a typical temperature calibration application (a 25Ω SPRT against a 100Ω reference resistor), which is clearly too high.

The microK uses a cascode stage after the main current source to improve the output impedance (figure 8):

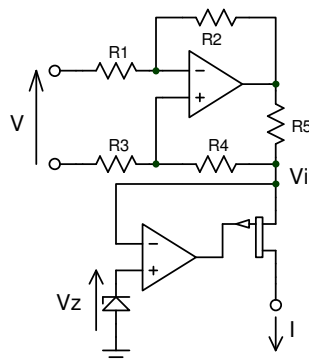

Figure 8: Current source with cascode stage.

The second operational amplifier controls the gate of the FET so that the voltage at the output of the current source (V_i) is controlled to V_z . The output of the main current source now no longer changes as the load switches between R_x and R_o . An analysis of the circuit as implemented in the microK shows that the output impedance now increases to $700\text{M}\Omega$. The maximum error (with $R_o=100\Omega$) would then be 0.036ppm , which is insignificant compared with the instrument’s specified accuracy of 0.4ppm .

Additionally, since the FET is essentially a current source, the circuit relies to a much lower extent on the loop gain to regulate the current. This improves settling times (important in a reversing ‘DC’ measurement system) and improves immunity to noise and transients picked up on the leads connecting the instrument to the DUT.

Although the above analysis shows that the inclusion of a cascode stage reduces the errors caused by the current source to insignificant proportions, the measurement system in the microK is also actively guarded to further improve performance (figure 9).

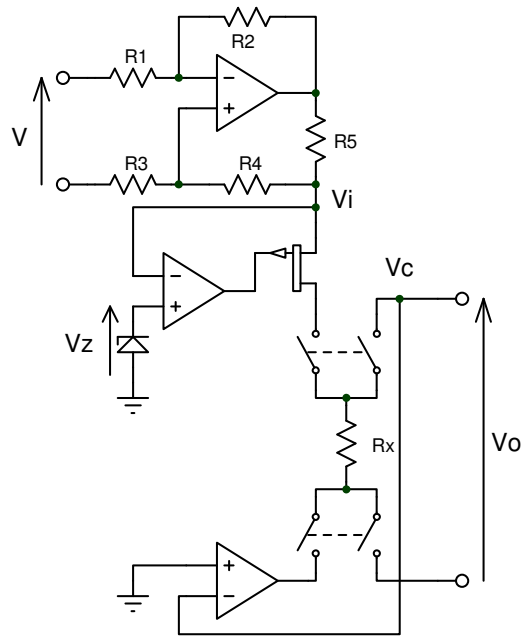

Figure 9: Guarded current source.

The third operational amplifier sinks the current supplied to R_x and maintains the voltage at the output of the cascode stage (V_c) at zero. This approach reduces the effect of the current source output impedance to zero.

In the microK, a separate operational amplifier is used for each channel. This means that there will be a small change in V_c as R_x and R_o are switched alternately into the measurement position (due to the different offset voltage for each amplifier). The maximum offset voltage for the operational amplifier used is 0.8mV, so taking a very worst case view, the maximum change in V_c would be 1.6mV. This would in turn lead to an error in the measured ratio (with $R_o=100\Omega$ and a sense current of 1mA) of 0.0023ppm, which is insignificant compared with the microK's accuracy specification of 0.4ppm.

4 Substitution Bridge Topology

Although the microK measurement system described above appears to be a potentiometric arrangement, the fact that the internal zener reference is used by both the current source and the ADC means that it is in fact a bridge system. The specially developed Sigma-Delta ADC balances the voltage developed across R_x or R_o against the reference voltage from the zener using a pulse-width modulation (PWM) digital-to-analog converter (DAC). Figure 10 shows this arrangement (with the cascode stage omitted for clarity).

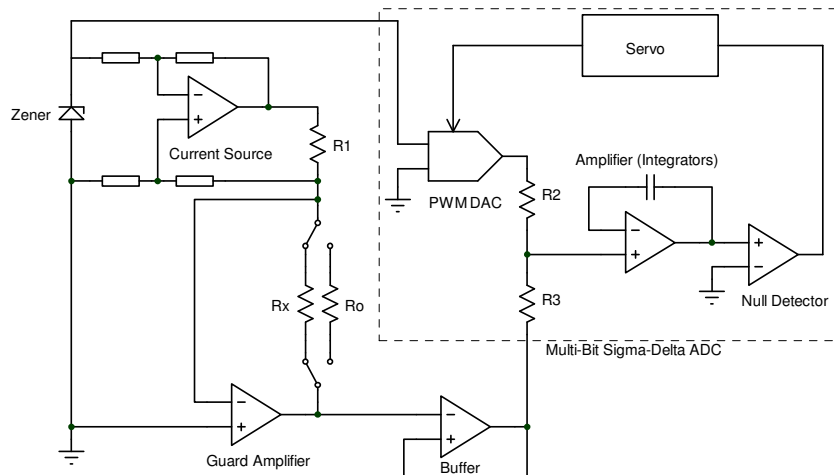

Figure 10: microK bridge measurement system.

The two arms of the bridge are formed from R1 (the sense resistor on the current source) in series with either Rx or Ro and R2 in series with R3 (part of the sigma-delta ADC circuit). The bridge is continuously balanced by a digital servo system in the sigma-delta ADC that adjusts the PWM DAC to maintain a null. The voltage across R1 is controlled to be a proportion of the zener voltage, so as with other bridges the ‘supply’ noise (in this case the noise from the zener) is common to both arms for the bridge and at balance does not affect the measurement.

The adjustable element used to balance the bridge is the PWM DAC. This is essentially digital, relying on the ability of the circuit to produce accurately timed pulses to modulate the voltage from the zener reference. This can, of course, be implemented with considerable accuracy and is very stable with time and temperature.

This substitution bridge topology differs from conventional bridges in that the DUT (Rx) and reference resistor (Ro) are successively switched into a single measurement position. The ratio of these two measurements is then calculated in order to determine the ratio of their resistance. As well as providing an inherently true zero and unity ratio, the substitution topology means that (unlike conventional bridges) the measurements are insensitive to the accuracy of the resistors R1 to R3 in the bridge. The value of these resistors is eliminated from the result when taking the ratio of the measurements on Rx and Ro, the bridge resistors are therefore only required to remain stable during the measurement time. With the speed of the microK’s ADC (full accuracy conversion in 100ms), any effect from drift in the values of R1 to R3 is negligible.

5 Test Results

A sample of nine production microK units was checked for zero and unity ratio accuracy. The zero ratio was checked by applying a four-terminal short-circuit to the input terminals. The unity ratio accuracy was checked by measuring the ratio (R) of two resistors with a nominal resistance of 100Ω and then swapping over the two resistors and measuring the inverse ratio (R’). Both measurements are near to unity and since the error function of the measurement system will change smoothly over the limited range used (<1% of scale), the error at unity closely approximates to:

$$\text{Complement Error} = \frac{RR' - 1}{2}$$

The fast reversals used in the microK mean that the instrument's resistance measuring function has a very small warm-up drift. To test this, these zero and unity ratio check tests were performed on 'cold' units. A sufficient number of measurements were taken to ensure that the uncertainty of measurement is below 0.01ppm. The results are shown in figure 11.

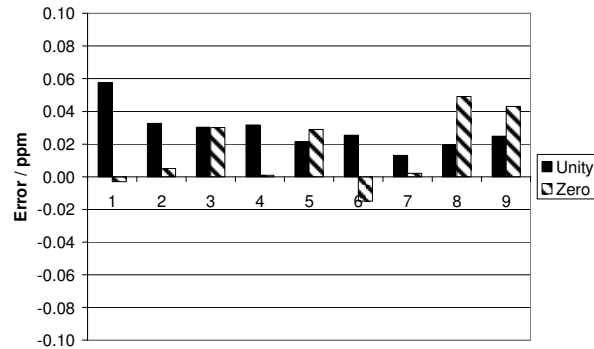

Figure 11: Zero and unity error test results.

6 Conclusions

The established wisdom is that the best measurements with resistance thermometers are made using a bridge (usually an AC transformer based bridge). A substitution bridge topology offers some significant advantages over conventional bridge arrangements. In particular, the substitution topology provides inherent accuracy and stability at both zero and unity ratio.

A substitution topology is more complicated and therefore expensive to realize, but the additional costs are modest in view of the performance advantages it offers. This alternative topology does place higher demands on the performance of the current source used in the system, but these can be overcome by using a cascode stage and active guarding, without adding excessive circuit complexity and cost. Using a substitution bridge topology and a suitable current source, the new microK precision thermometer is able to offer resistance measurement accuracy of better than 0.4ppm (equivalent to 0.4mK in typical temperature calibration applications). Although this paper describes the benefits of a substitution topology to resistance measurement, the principles can equally be applied to the measurement of other parameters such as capacitance or inductance in order to gain similar performance benefits.

7 Reference

1. A Guide to Measuring Resistance and Impedance Below 1MHz, Institute of Measurement & Control, ISBN 0 904457 31 1, page 27, 1999
2. I. Warshawsky, Multiple-Bridge Circuits for Measurement of Small Changes in Resistance, The Review of Scientific Instruments, Vol. 26 N^o 7, pages 711 to 715, 1955

3. P. Bramley, J. Yewen, D. Stanley, A 20ppb Resistance Bridge For Use In Temperature Metrology, NCSLi Conference Proceedings, 2000
4. P. Bramley, J. Pickering, Better Accuracy in Temperature Calibration and Measurement Achieved Through the Use of a New Type of Analog-to-Digital Converter, Cal Lab Magazine, pages 30-35, October 2006